

Instructions–Parts List



3:1 Fireball 225 or 5:1 Fireball 300 Portable Gear Lube Pump

307884S
ENG

For dispensing fluid in stationary or mobile installations. For professional use only.

Model 246903 – 3:1 Fireball 225 Pump

540 psi (3.7 MPa, 37 bar) Maximum Working Pressure

Model 225728 – 5:1 Fireball 300 Pump

900 psi (6.2 MPa, 62 bar) Maximum Working Pressure

Includes dispense kit, roll-around base, and drum cover

WARNING

This system is designed to be used **only** in pumping non-corrosive and non-abrasive lubricants. Any other use of the system can cause unsafe operating conditions and result in component rupture, fire, or explosion, which can cause serious bodily injury, including fluid injection.



Important Safety Instructions

Read all warnings and instructions in this manual.
Save these instructions.

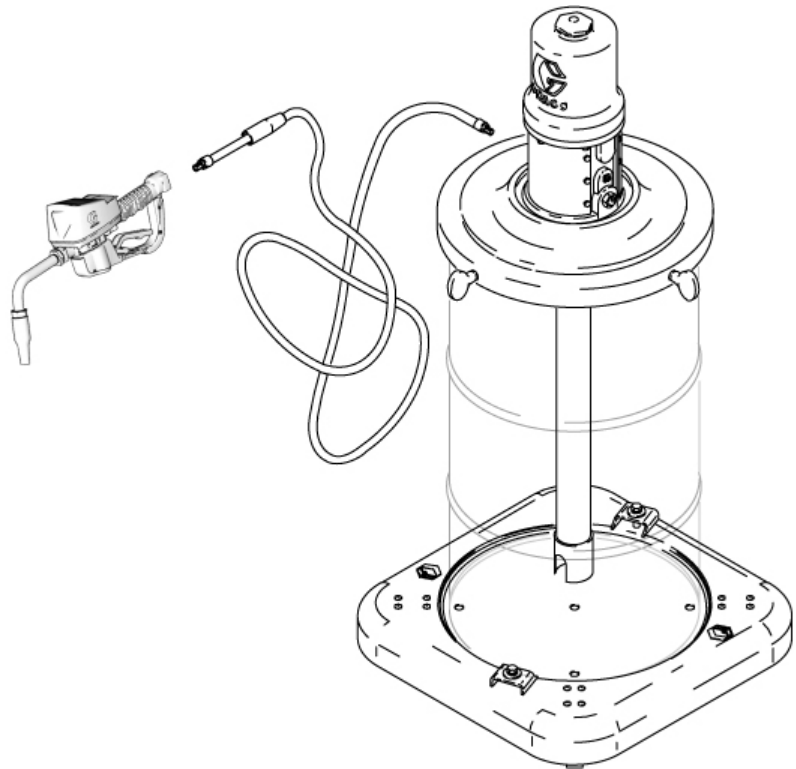

H003

PROVEN QUALITY. LEADING TECHNOLOGY.

Warnings

WARNING



EQUIPMENT MISUSE HAZARD

Equipment misuse can cause the equipment to rupture or malfunction and result in serious injury.

- This equipment is for professional use only.
- Read all instruction manuals, tags, and labels before operating the equipment.
- Use the equipment only for its intended purpose. If you are not sure, call your Graco distributor.
- Do not alter or modify this equipment. Use only genuine Graco parts and accessories.
- Check equipment daily. Repair or replace worn or damaged parts immediately.
- Do not exceed the maximum working pressure stated on the equipment or in the **Technical Data** section for your equipment. Do not exceed the maximum working pressure of the lowest rated component in your system.
- Use fluids and solvents that are compatible with the equipment wetted parts. Refer to the **Technical Data** section of all equipment manuals. Read the fluid and solvent manufacturer's warnings.
- Handle hoses carefully. Do not pull on hoses to move equipment.
- **All fluid hoses must have spring guards on both ends.** The spring guards help protect the hose from kinks or bends at or close to the coupling, which can result in hose rupture.
- Route hoses away from traffic areas, sharp edges, moving parts, and hot surfaces. Do not expose Graco hoses to temperatures above 82°C (180°F) or below -40°C (-40°F).
- Do not lift pressurized equipment.
- Comply with all applicable local, state, and national fire, electrical, and safety regulations.
- Be sure you know the maximum working pressure of the flexible nozzle you are using. Never use a flexible nozzle designed for low pressure dispensing valves or hand-powered lubricating equipment on a high pressure dispensing valve.
- Do not modify any part of the dispensing valve; doing so could cause a malfunction and result in serious bodily injury. Be sure the dispensing valve has a maximum working pressure that meets or exceeds that of the pump.
- The maximum fluid working pressure of these pumps, when operated at a maximum of 180 psi (1.2 MPa, 12 bar) air pressure is **900 psi (6.2 MPa, 62 bar)**.

WARNING



INJECTION HAZARD

High pressure fluid from dispense device, hose leaks or ruptured components will pierce skin. This may look like just a cut, but it is a serious injury that can result in amputation. **Get immediate surgical treatment.**

- Do not point the dispensing device at anyone or at any part of the body.
- Do not put your hand or fingers over the fluid outlet.
- Do not stop or deflect leaks with your hand, body, glove, or rag.
- Follow **Pressure Relief Procedure** in this manual, when you stop dispensing and before cleaning, checking or servicing equipment.
- Tighten all fluid connections before operating the equipment.
- Check the hoses, tubes, and couplings daily. Replace worn or damaged parts immediately.



HAZARDOUS FLUIDS

Improper handling of hazardous fluids or inhaling toxic fumes can cause extremely serious injury or death due to splashing in the eyes, ingestion, or bodily contamination.

- Know the specific hazards of the fluid you are using.
- Store hazardous fluid in an approved container. Dispose of hazardous fluid according to all local, state, and national guidelines.
- Always wear protective eyewear, gloves, clothing, and respirator as recommended by the fluid and solvent manufacturer.



FIRE AND EXPLOSION HAZARD

Improper grounding, poor ventilation, open flames, or sparks can cause a hazardous condition and result in a fire or explosion and serious injury.

- Ground the equipment. Refer to **Grounding** below.
- If there is any static sparking or you feel an electric shock while using this equipment, **stop dispensing immediately.** Do not use the equipment until you identify and correct the problem.
- Provide fresh air ventilation to avoid the buildup of flammable fumes from solvents or the fluid being dispensed.
- Do not smoke in the dispensing area.

WARNING



MOVING PARTS HAZARD

Moving parts can pinch or amputate your fingers.

- Keep clear of all moving parts when starting or operating the pump.
- Before servicing the equipment, follow the **Pressure Relief Procedure** on page 8 to prevent the equipment from starting unexpectedly.

United States Government safety standards have been adopted under the Occupational Safety and Health Act. You should consult these standards—particularly General Standards, Part 1910, and Construction Standards, Part 1926.

Installation

Grounding

To reduce the risk of static sparking, ground the pump. Check your local electrical code for detailed grounding instructions for your area and type of equipment.

- *Pump:* Use ground wire and clamp as shown in Fig. 1.
- *Air and fluid hoses:* Use only grounded hoses.
- *Air compressor:* Follow manufacturer's recommendations.
- *Dispensing valve:* Obtain grounding through connection to a properly grounded fluid hose and pump.
- *Fluid supply container:* Follow your local code.
- *Object being lubricated:* Follow your local code.
- *Any pails used when flushing:* Use only metal, grounded pails when flushing. Make firm metal-to-metal contact between a metal part of the dispensing valve and the pail. Use the lowest possible pressure.
- *To maintain grounding continuity when flushing or relieving pressure,* always hold a metal part of the dispensing valve firmly to the side of a *metal pail*, and then open the dispensing valve.

To ground the pump, remove ground screw (Z) and insert through the eye of the ring terminal at end of ground wire (Y). Fasten ground screw back onto pump and tighten securely. Connect the other end of ground wire to a true earth ground. See Fig. 1. *To order a ground wire and clamp, order Part No. 222011.*

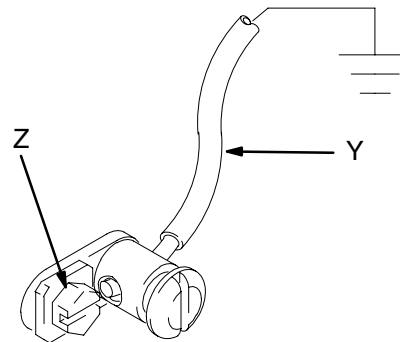

Fig. 1

T11052

Installation

The typical installation shown in Fig. 2 is only an installation guide; it is not an actual system design. Contact your Graco distributor for assistance in designing a system to suit your needs.

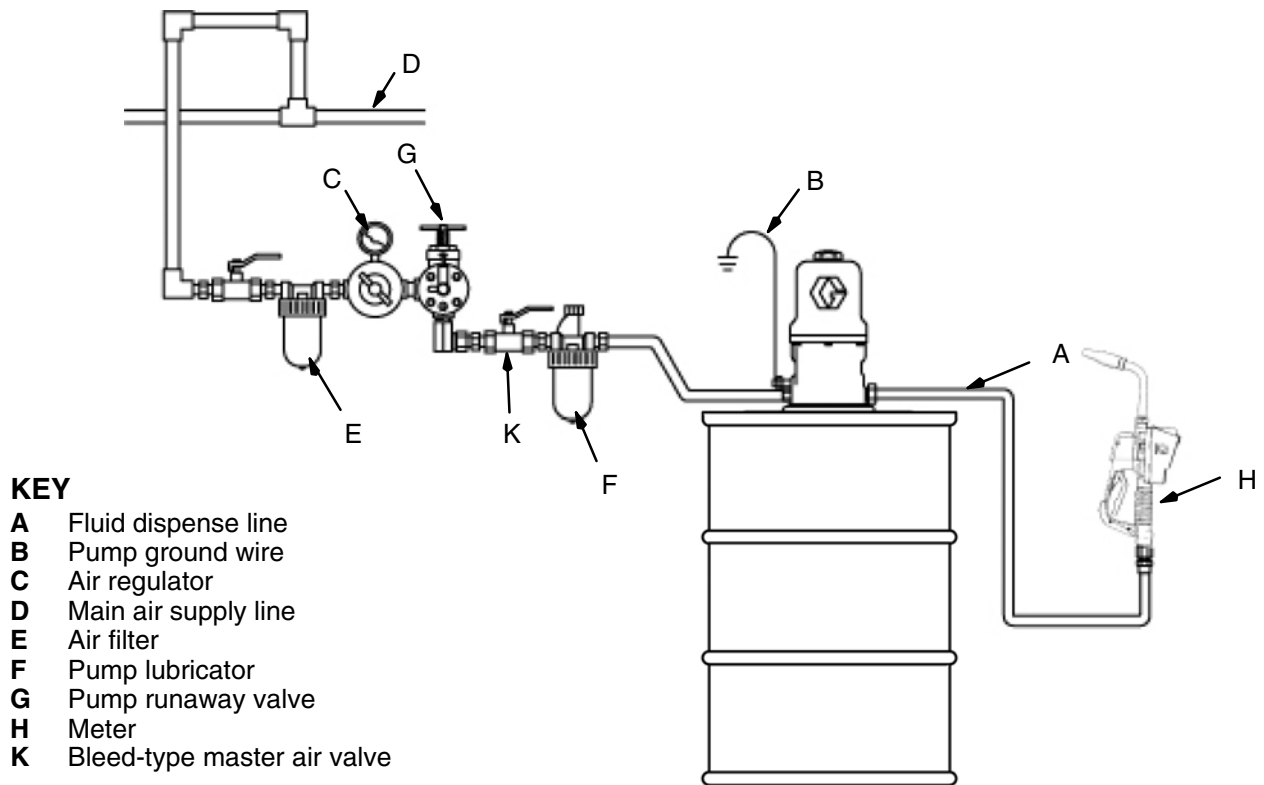

Fig. 2

04044B

See Parts Drawing on page 10

Place an open 16-gallon (60-liter) steel drum (J) on the base (3).

Secure the drum with the hold down clamps (3c) and hex head bolts (3c).

Place the drum cover (4) on the drum, and fasten it with the screws and washers provided. Carefully guide the pump riser tube through the mounting gasket. Refer to the assembled view of Model 225728 on the front cover.

Installation

Air and Fluid Line Accessories

NOTE: Install the accessories in the order shown in Fig. 2 on page 5.

CAUTION

Do not hang the air accessories directly on the air inlet. Mount them on brackets. The fittings are not strong enough to support the accessories and may break.

- Install a bleed-type master air valve (K) upstream from the pump air regulator (C), but within easy reach of the pump.

To order a 300 psi (2.1 MPa, 21 bar) maximum working pressure, 1/2 in. npt bleed-type master air valve, order Part No. 107142.

WARNING

A bleed-type master air valve is required in the system to help reduce the risk of serious bodily injury, including fluid injection, splashing in the eyes, and injury from moving parts when adjusting or repairing the pump. This valve relieves air trapped between the valve and the pump to prevent the pump from cycling unexpectedly.

- Install a pump runaway valve (G) to shut off the air to the pump if the pump accelerates beyond the pre-adjusted setting. A pump that runs too fast can be seriously damaged.

To order a pump runaway valve, order Part No. 224040.

- Install an air line lubricator (F) for automatic air motor lubrication.

To order a 250 psi (1.74 MPa, 17.4 bar) maximum working pressure air line lubricator, order a Part No. below:

<i>3/8 in. npt</i>	<i>214847</i>
<i>1/2 in. npt</i>	<i>214848</i>

- Install an air regulator (C) to control pump speed and pressure.

To order a 300 psi (2.1 MPa, 21 bar) maximum working pressure regulator, order a Part No. below:

<i>3/8 in. npt</i>	<i>109075</i>
<i>1/2 in. npt</i>	<i>244844</i>

- Install an air line filter (E) to remove harmful dirt and contaminants from your compressed air supply.

To order a 250 psi (1.74 MPa, 17.4 bar) maximum working pressure air filter, order a Part No. below:

<i>3/8 in. npt</i>	<i>106148</i>
<i>1/2 in. npt</i>	<i>214849</i>

Installation

Dispense Kit (Parts 2a and 2b)

Connect the hose (2a) to the pump outlet.

Connect the dispense valve (2b) to the hose (2a).

Air Regulator Kit (Parts 5a – 5d)

KEY

- 2a Fluid hose
- 2b Dispense valve

- 5a Regulator, air, 3/8 npt (f) 0–250 psi (17.4 bar)
- 5b Gauge, air pressure
- 5c Valve, air bleed-type 3/8 npt (f)
- 5d Nipple, 3/8 npt

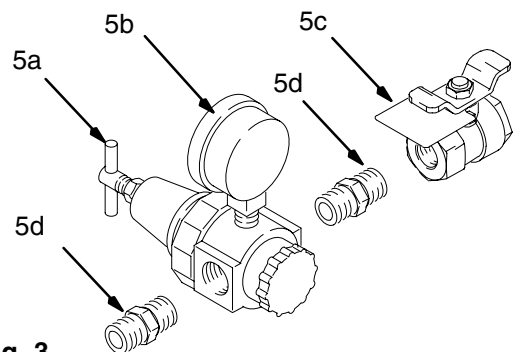
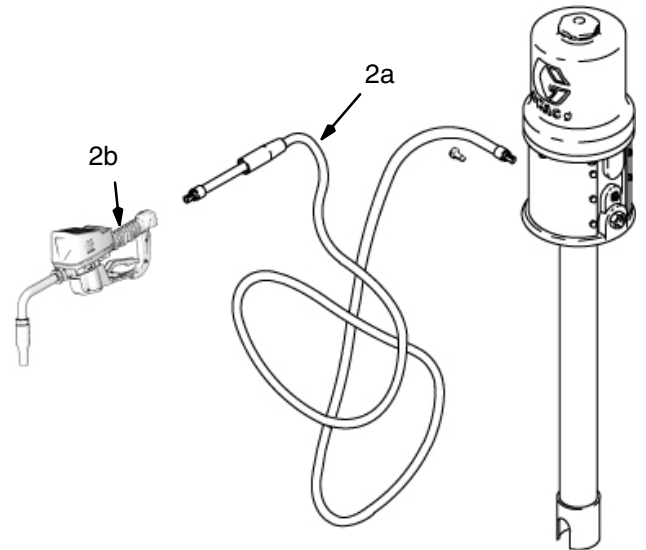



Fig. 3

Operation

Pressure Relief Procedure

! WARNING



INJECTION HAZARD
To reduce the risk of serious bodily injury, including fluid injection, injury from moving parts, or splashing in the eyes or on the skin, always follow this procedure whenever you shut off the pump, when checking or servicing any part of the system, when installing or changing dispensing devices, and whenever you stop dispensing.

1. Close the pump air regulator.
2. Close the pump's bleed-type master air valve (required in the system).
3. Hold a metal part of the gun or valve firmly to a grounded metal waste container and trigger to relieve the fluid pressure.

*If you suspect that the dispensing valve is clogged, or that pressure has not been fully relieved after following the steps above, **very slowly** loosen the dispensing valve coupler or hose end coupling to relieve pressure gradually, then loosen completely. Then clear the clog.*

Operation

Startup

WARNING

The maximum working pressure of each pump in your system may not be the same. To reduce the risk of overpressurizing any part of your system, be sure you know the maximum working pressure rating of each pump and its connected components. Never exceed the maximum working pressure of the lowest rated component connected to a particular pump.

To determine the fluid output pressure using the air regulator reading, multiply the ratio of the pump by the air pressure shown on the regulator gauge. For example:

5:(1) ratio x 100 psi air = 500 psi fluid output

[5:(1) ratio x 0.7 MPa (7 bar) air =
3.5 MPa (35 bar) fluid output]

Limit the air to the pump so that no air line or fluid line component or accessory is over-pressurized.

1. Open the master air valve from the compressor.
2. Trigger the dispensing valve into a grounded metal waste container, making firm metal-to-metal contact between the container and valve.
3. Open the bleed-type master air valve, and open the pump air regulator slowly, just until the pump is running. When the pump is primed and all air has been pushed out of the lines, release the trigger.

NOTE: When the pump is primed, and with sufficient air supplied, the pump starts when the dispensing valve is opened and shuts off when it is closed.

4. Set the air pressure to each pump at the lowest pressure needed to get the desired results. Use the regulator to adjust pump speed and pressure.

CAUTION

Never allow the pump to run dry of the fluid being pumped. A dry pump quickly accelerates to a high speed and could possibly damage itself. If the pump accelerates quickly, stop it immediately, and check the fluid supply. If the supply container is empty and air has been pumped into the lines, prime the pump and lines with fluid, or flush it and leave it filled with a compatible solvent. Be sure to eliminate all air from the fluid system.

NOTE: A pump runaway valve can be installed on the air line to automatically shut off the pump if it starts to run too fast. See **Air and Fluid Line Accessories** on page 6.

5. Read and follow the instructions supplied with each component in your system.
6. To shut off the system, always **relieve the pressure**.

WARNING



INJECTION HAZARD

To reduce the risk of serious injury whenever you are instructed to relieve pressure, always follow the **Pressure**

Relief Procedure at left.

Parts Drawing

Model 246903

3:1 Ratio Fire-Ball 225 Portable Gear Lube Pump
with Drum Cover

Model 225728

5:1 Ratio Fire-Ball 300 Portable Gear Lube Pump
with Drum Cover

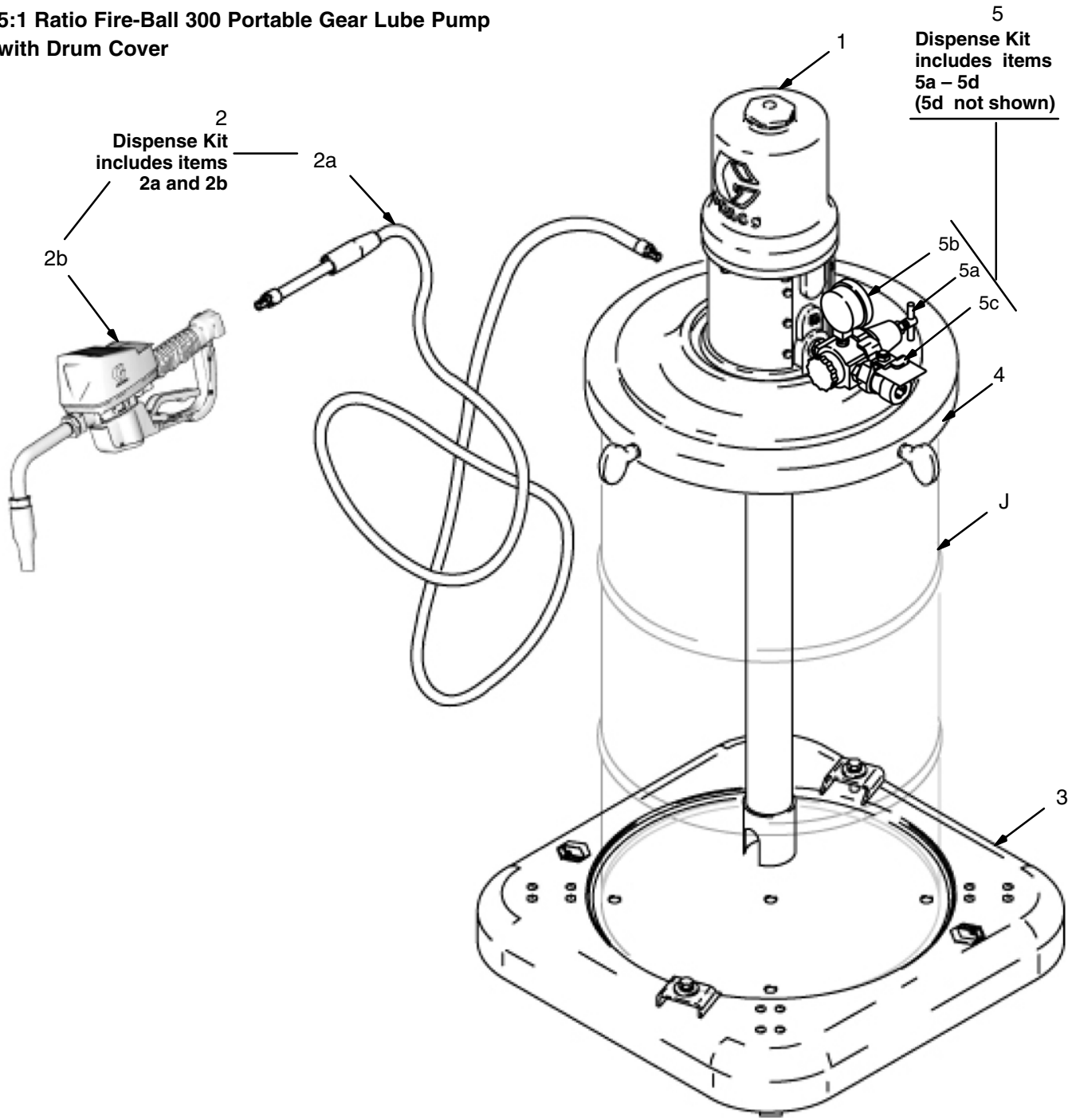

Parts Lists

Model 246903

3:1 Ratio Fire-Ball 225 Portable Gear Lube Pump
with Drum Cover

Model 225728

5:1 Ratio Fire-Ball 300 Portable Gear Lube Pump
with Drum Cover

Ref. No.	Part No.	Description	Qty.
1	248097	PUMP, 3:1 Ratio Fire-ball; used on model 245903 <i>See manual 309868 for parts.</i>	1
	203872	PUMP, 5:1 Ratio Fire-ball; used on model 225728 <i>See manual 306518 for parts.</i>	1
2	237075	KIT, DISPENSE; <i>Includes items 101 and 102. See separate Parts List at right.</i>	1
3	203622	PORTABLE BASE <i>See manual 308668 for parts.</i>	
4	204574	DRUM COVER <i>See manual 306345 for parts.</i>	1
5	224512	KIT, AIR REGULATOR <i>See manual parts list.</i>	1

Ref. No. 2 Dispense Kit 237075, Series B

Ref. No.	Part No.	Description	Qty.
2a	220591	HOSE, fluid; 1/2" ID; cpld 1/2 x 1/2 npt(mbe); 72"	1
2b	255349	DISPENSING VALVE; <i>See manual 312865 for parts.</i>	1

Ref. No. 5 Air Regulator Kit 224512

Ref. No.	Part No.	Description	Qty.
5a	110234	REGULATOR, air; 3/8 npt(f); 0–250 psi (0–1.7 MPa, 0–17.4 bar) range; see manual 308167	1
5b	100960	GAUGE, air pressure	1
5c	110224	VALVE, air, bleed-type; 3/8 npt(f)	1
5d	156849	NIPPLE; 3/8 npt	2

Graco Standard Warranty

Graco warrants all equipment manufactured by Graco and bearing its name to be free from defects in material and workmanship on the date of sale by an authorized Graco distributor to the original purchaser for use. With the exception of any special, extended, or limited warranty published by Graco, Graco will, for a period of twelve months from the date of sale, repair or replace any part of the equipment determined by Graco to be defective. This warranty applies only when the equipment is installed, operated and maintained in accordance with Graco's written recommendations.

This warranty does not cover, and Graco shall not be liable for general wear and tear, or any malfunction, damage or wear caused by faulty installation, misapplication, abrasion, corrosion, inadequate or improper maintenance, negligence, accident, tampering, or substitution of non-Graco component parts. Nor shall Graco be liable for malfunction, damage or wear caused by the incompatibility of Graco equipment with structures, accessories, equipment or materials not supplied by Graco, or the improper design, manufacture, installation, operation or maintenance of structures, accessories, equipment or materials not supplied by Graco.

This warranty is conditioned upon the prepaid return of the equipment claimed to be defective to an authorized Graco distributor for verification of the claimed defect. If the claimed defect is verified, Graco will repair or replace free of charge any defective parts. The equipment will be returned to the original purchaser transportation prepaid. If inspection of the equipment does not disclose any defect in material or workmanship, repairs will be made at a reasonable charge, which charges may include the costs of parts, labor, and transportation.

THIS WARRANTY IS EXCLUSIVE, AND IS IN LIEU OF ANY OTHER WARRANTIES, EXPRESS OR IMPLIED, INCLUDING BUT NOT LIMITED TO WARRANTY OF MERCHANTABILITY OR WARRANTY OF FITNESS FOR A PARTICULAR PURPOSE.

Graco's sole obligation and buyer's sole remedy for any breach of warranty shall be as set forth above. The buyer agrees that no other remedy (including, but not limited to, incidental or consequential damages for lost profits, lost sales, injury to person or property, or any other incidental or consequential loss) shall be available. Any action for breach of warranty must be brought within two (2) years of the date of sale.

Graco makes no warranty, and disclaims all implied warranties of merchantability and fitness for a particular purpose in connection with accessories, equipment, materials or components sold but not manufactured by Graco. These items sold, but not manufactured by Graco (such as electric motors, switches, hose, etc.), are subject to the warranty, if any, of their manufacturer. Graco will provide purchaser with reasonable assistance in making any claim for breach of these warranties.

In no event will Graco be liable for indirect, incidental, special or consequential damages resulting from Graco supplying equipment hereunder, or the furnishing, performance, or use of any products or other goods sold hereto, whether due to a breach of contract, breach of warranty, the negligence of Graco, or otherwise.

FOR GRACO CANADA CUSTOMERS

The parties acknowledge that they have required that the present document, as well as all documents, notices and legal proceedings entered into, given or instituted pursuant hereto or relating directly or indirectly hereto, be drawn up in English. Les parties reconnaissent avoir convenu que la rédaction du présente document sera en Anglais, ainsi que tous documents, avis et procédures judiciaires exécutés, donnés ou intentés à la suite de ou en rapport, directement ou indirectement, avec les procédures concernées.

Graco Information

For the latest information about Graco products, visit www.graco.com.

TO PLACE AN ORDER, contact your Graco distributor or call to identify the distributor closest to you:

Phone: 612-623-6928 or **Toll Free:** 1-800-533-9655 **Fax:** 612-378-3590

All written and visual data contained in this document reflects the latest product information available at the time of publication.

Graco reserves the right to make changes at any time without notice.

Original instructions. This manual contains English. MM 307884

Graco Headquarters: Minneapolis

International Offices: Belgium, China, Japan, Korea

GRACO INC. P.O. BOX 1441 MINNEAPOLIS, MN 55440-1441

Copyright 1988, Graco Inc. is registered to ISO 9001

www.graco.com

Revised 06/2010